

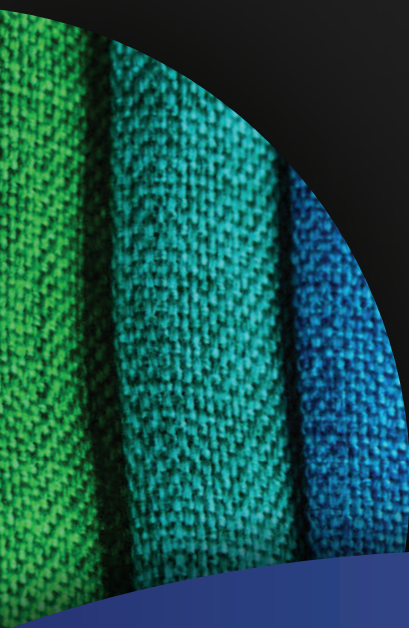

Textile Printing & Drying Solutions

Product Catalog



www.adelco.co.uk

Adelco Product Ranges

Drying Solutions Innovative Drying Systems

We offer a range of versatile textile drying systems, for both conventional and digital ink systems, with different throughput capabilities to suit your business needs.

Page

3-6:	Adelco Pro-Cure
7-10:	Adelco Dual
11-14:	Adelco Digi-Cure
15-18:	Adelco Drawer Drying Cabinets

Screen Printing Systems

A choice of oval and carousel printing systems with unique features to increase throughput efficiency, accuracy and maximise print quality.

Page

19-22:	Adelco Cyclone
23-26:	Adelco Matrix Oval
27-30:	Adelco Ellipse Oval
31-32:	Adelco AD Hybrid Digital
33-36:	Adelco Flash Cure

Digital Printers

Advanced Digital Textile Printers

The GOTO high-speed, fully automated direct to garment printer with unrivalled print quality

Page

37-38: OvalJet

Folding Equipment

Efficient Post-Print Machinery

Simplify your process with our must-have range of efficient automatic folding machines and packaging equipment.

Page

39: Thermotron Folding and stacking machine - FX25
40: Thermotron Folding Module - STP1000
40: Thermotron Bagging module - PV40
40: Thermotron Sealing module - KL60
41: Thermotron Barcode label printing module BC41
41: Thermotron Stacking module - NT50
42: Thermotron - The Complete Station

Ancillaries

Page

43: Spyder II
44: Cyclone Semi-Auto
44: Manual Carousel
44: Temperature Mapping Kits
44: Pre-Registration System
44: Table Flash
44: Auto Flock Unit
44: Flock Cleaner
44: Ink Processor
44: Exile V-Lux

adelco PRO-CURE

An advanced textile conveyor dryer that cures both **screen & digitally printed garments with five belt width options** to meet your production output requirements.

Standard Features

- Integral indeed and outfeed exhausts
- Five belt widths available.
- Ovens are fully modular enabling dryer length to be chosen to suit all curing requirements (expansions available).
- Automatic belt speed control. Just enter the time in minutes and seconds to precisely adjust the speed of your belt.
- Triple insulation with air curtain for the coolest exterior shell available.
- Air intake from both sides of oven giving unrivaled heat distribution.

Integral feed and outfeed exhausts remove chemicals and contaminated air from the workplace



Integral exhaust adjustment



Air curtain cooling maintains a cool outer shell

The strongest, toughest and longest lasting conveyor belts on the market

Auto tension, self-tracking rollers

Highly efficient, direct burner system



New Features

- Features new vacuum pull-down that provides exceptional stability of delicate fabrics preventing lifting/flipping of fabrics or transfer paper whilst under high velocity jet air curing technology.
- Even higher airflow through the garment for increased airflow penetration leading to faster curing times, and unmatched wash fastness.
- Features new "Eco Extractor Plus technology" which utilizes more clean filtered air whilst extracting contaminated air and fumes and still maintaining superior energy efficiency levels.
- The new touchscreen interface design is easier to navigate and reacts faster.
- Unique built in hood extraction helps prevent fumes from escaping in to your factory as products enter and exit the oven for a cleaner, more pleasant working environment.
- Fast & easy to clean fine filtration system that can be cleaned even whilst the dryer is running, no replacement filters required.
- Reduced energy consumption for the lowest running costs
- Integral exhaust connected from top of dryer with easily adjustable exhaust outlet valve
- Removable panels for easy cleaning access



Split belt models



4 meter model



5 meter model



6 meter model



Optional VOC (Volatile Organic Compounds) exhaust filtration system



The strongest jet airflow on the market with an integrated vacuum utilizes new technology in curing and ink penetration

Recycles clean filtered air

Optional cooling modules and bridges



The worlds easiest maintainable curing system allows for quick and optimized servicing



Sophisticated fold away touch screen



Small quick release lint filters for simple/fast maintenance, even whilst the dryer is running, no replacement filters required.

Production Capacities (Based on 3 meter oven length)

Model	PC 75	PC 100	PC 120	PC 150	PC 180
1 minute (Plastisol Ink)	360/hour	360/hour	720/hour	720/hour	1080/hour
2 mins (Waterbased/Discharge Ink)	180/hour	180/hour	360/hour	360/hour	540/hour
3 mins (Kornit Digital no white ink/light coloured fabrics)	120/hour	120/hour	240/hour	240/hour	360/hour
7 mins (Kornit Digital with white ink/dark coloured fabrics)	52/hour	52/hour	104/hour	104/hour	156/hour

Based on a 3 M oven length. Production increases 30% for a 4 M oven, 60% for a 5 M oven and 100% for a 6 M oven and decreases by 30% for a 2 M oven. Allowing for one line of garments to be placed every 50cm. One line of products on 75cm and 100cm belts, two lines on 120cm and 150cm and three lines on 180cm. Production rates will alter depending on the product placement and the time/temperature settings chosen for the individual curing requirements. Wash tests should be undertaken to ensure the correct time and temperature combination for specific ink types.

Gas Dryer Specifications

Description	PC75G-3	PC100G-3	PC120G-3	PC150G-3	PC180G-3
Electrical Supply Voltages confirmed at time of ordering. Other voltages available on request	3Phase, 50/60HZ 200/220V & 380/415V	3Phase, 50/60HZ 200/220V & 380/415V	3Phase, 50/60HZ 200/220V & 380/415V	3Phase, 50/60HZ 200/220V & 380/415V	3Phase, 50/60HZ 200/220V & 380/415V
Natural Gas Pressure	10" W. G/ 25mbar	10" W. G/ 25mbar	10" W. G/ 25mbar	10" W. G/ 25mbar	10" W. G/ 25mbar
Natural Gas Connection	3/4" BSP	3/4" BSP	3/4" BSP	3/4" BSP	3/4" BSP
Propane Gas Pressure	Line Pressure Reduced to 37mb	Line Pressure Reduced to 37mb	Line Pressure Reduced to 37mb	Line Pressure Reduced to 37mb	Line Pressure Reduced to 37mb
Propane Gas Connection	1/4" BSP	1/4" BSP	1/4" BSP	1/4" BSP	1/4" BSP
BTU REQUIRED	125,000	150,000	175,000	200,000	225,000
Time From ambient temp to 160 °C	Approximately 8 mins	Approximately 8 mins	Approximately 10 mins	Approximately 12 mins	Approximately 15 mins
Maximum Electrical Consumption	3Kw	4.5Kw	4.5Kw	4.5Kw	4.5Kw
Exhaust Dia	200mm (8 Inch)	200mm (8 Inch)	250mm (10 Inch)	250mm (10 Inch)	250mm (10 Inch)

Electric Dryer Specifications

Description	PC75E-2	PC75E-3	PC100E-2	PC100E-3	PC120E-3	PC150E-3	PC180E-3
Electrical Supply Voltages confirmed at time of ordering. Other voltages available on request	3Phase, 50/60HZ 200/220V & 380/415V	3Phase, 50/60HZ 200/220V & 380/415V	3Phase, 50/60HZ 200/220V & 380/415V	3Phase, 50/60HZ 200/220V & 380/415V	3Phase, 50/60HZ 200/220V & 380/415V	3Phase, 50/60HZ 200/220V & 380/415V	3Phase, 50/60HZ 200/220V & 380/415V
Maximum Electrical Consumption	20Kw/h	26Kw/h	28Kw/h	40Kw/h	40Kw/h	58Kw/h	58Kw/h
Average Electrical Consumption at 180 °C	14Kw/h	18Kw/h	20Kw/h	28Kw/h	30Kw/h	40Kw/h	40Kw/h
No & KW of Elements	9x2Kw (18Kw)	12x2Kw (24Kw)	9x3Kw (27Kw)	12x3Kw (36Kw)	12x3Kw (36Kw)	18x3Kw (54Kw)	18x3Kw (54Kw)
Exhaust Dia	150mm (6 Inch)	150mm (6 Inch)	200mm (8 Inch)	200mm (8 Inch)	250mm (10 Inch)	250mm (10 Inch)	250mm (10 Inch)

6 meter model



3 meter model



4 meter model



5 meter model



The new Adelco Pro-Cure conveyor dryer range is available in five belt widths and five oven lengths, so you can customize your dryer to suit your individual curing requirements, for all digital and conventional textile ink systems. The Pro-Cure is modular in design, making it the perfect option to add additional ovens to the dryer as your business grows.

Designed and specified for advanced textile curing, the Pro-Cure tunnel dryer has an efficient airflow and exhaust system, incorporating oven feed and exit extraction hoods to provide a cleaner working environment. As well as incorporating many of the popular features found in the Adelco Dual Dryer and our other drying systems.

The Adelco Pro-Cure is a feature rich conveyor dryer that uses dual lint filters to prevent the build-up of lint in the dryer and helps to reduce cleaning and maintenance dramatically. Filters can be easily cleaned in seconds while the dryer is still running. With many features included as standard, there are also some optional extras available to enhance your Pro-Cure dryer further.

The Pro-Cure is available as a gas or electric conveyor dryer and uses a sophisticated touch-screen control panel so you can easily set, manage and control the automatic belt speed that is precise and repeatable every time.

The Pro-Cure conveyor dryer offers a split-belt model in all oven sizes with two burners, two speeds and two directions, enabling the dryer to cure two independent ink systems at the same time. The Adelco Pro-Cure dryer comes with the strongest, toughest and longest lasting conveyor belts on the market.

PRO-CURE gas dryer consumption analysis

Belt Width	Oven Length	Average Gas Consumption		Average Electric Consumption	
		kg/hr	kwh	kwh	kwh
180cm	3 Meter	2.8	24.5	3.3	
	4 Meter	3.3	29	3.5	
	5 Meter	3.5	31	3.7	
	6 Meter	5.5	48.5	6.5	
150cm	3 Meter	2.6	23	3.2	
	4 Meter	3	26.5	3.4	
	5 Meter	3.2	28	3.6	
	6 Meter	5	44	5.8	
120cm	3 Meter	2.4	21	2.8	
	4 Meter	2.7	24	3	
	5 Meter	2.9	25.5	3.2	
	6 Meter	4.6	40.5	5.0	
100cm	2 Meter	2	18	2	
	3 Meter	2.2	19.5	2.2	
	4 Meter	2.4	21	2.3	
	5 Meter	2.5	22	2.4	
75cm	2 Meter	1.8	16	1.2	
	3 Meter	2	18	1.4	

Adelco figures taken from consumption tests, averaged per hour at 160 degrees, with exhaust closed. Consumption figures can change according to local environment, production throughput, ink and product types. Adelco reserve the right to revise or review these figures as required.

Touch Screen Control Panel

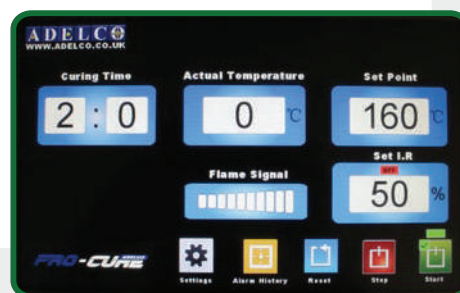

Touch panel features include:

- Belt speed adjustment. Enter the time required in the oven and watch the belt speed change automatically
- Digital temperature control
- Alarm history shows any safety or temperature fluctuation alarms with date and time recorded
- On screen flame signal

“Adelco is like a family to me, Adelco Dryers have strong money back – Good return, the problem is that they are too good.”

- Pally Hayre, Pally UK

adelco DUAL

The world's highest production and most **energy efficient dual conveyor** dryer for curing screen & digital ink systems.

Independent temperature control for both levels

Automatic self-tensioning conveyors

Independent belt speed control to both levels



The Adelco Dual has a unique built in extraction system on the infeed and outfeed for a cleaner working environment together with independent exhaust extraction from each conveyor to maximize the curing efficiency for heavily water laden prints in both digital and conventional printing requirements

Single internally integrated burner exhaust & extraction

Advanced airflow system incorporating high powered jet air and integrated vacuum pull down on both levels

15" HDMI touch screen control panel

Two Dryers, One Footprint.

- The Dual dryer from Adelco takes high production curing to a new level, with independent burners and temperature control for each conveyor
- Compact streamlined design
- Does the work of two dryers in a single dryer footprint
- The world's highest production & most energy efficient dryer
- The most technically advanced dryer on the market
- No other dryer on the market will cure digital inks in such high volume with such a small footprint

High Performance

High Production

Low Cost

Low Emissions

Description	DL-180-3
BTU Required	225,000 BTU X 2
Gas Pressure Input Natural	10"W.G/25mbar/each supply
Gas Pressure Input Propane	Line Pressure (reduced to 37mbar)/each
Gas Connection Natural	3/4"BSP/each
Gas Connection Propane	1/4"BSP/each
Electrical Supply	3 Phase 220V/380V/415V
Max Electrical Consumption	7KW
Time from ambient temp to 160°C (320°F)	Approximately 15 minutes
Exhaust Diameter	(12"BSP)300m

Time	Digital Print (Black Shirts)	Screen Print
1 Minute	/	2160 per hour
2 Minutes	/	1080 per hour
5 Minutes	430 per hour	
6 Minutes	360 per hour	
8 Minutes	270 per hour	
10 Minutes	216 per hour	

Based on three lines of adult size garments across each belt width. Allowing for one product placed every 50cm. Production rates will alter depending on product placement and time/temperature settings chosen for individual curing requirements.

The Adelco Dual dryer gets its name from its unique design. The Dual dryer is a double belt conveyor dryer with separate heat chambers, airflow and exhaust systems for the top and bottom conveyor belts.

Experience the benefits of two dryers in one footprint with the Adelco Dual dryer range. With dual tunnels, the Dual dryer increases the high throughput capabilities in both digital and conventional textile print requirements, without increasing the size of the dryer.

With independent burners, time and temperature controls for each conveyor level, the Dual cures digital and screen-printing inks in high volumes with such a small footprint.

All Adelco drying machines, including the Dual, and the range of Pro-Cure dryers, are fitted with internal exhaust hoods over the feed and exit sections of the oven. This provides a cleaner working environment without having to add optional extraction hoods and exhaust connections.





“Mark and Leigh Smith have been in the industry a long time and are the only owner-owned manufacturer/distributors in the industry. They’ll look at what you need and will then create a solution for you, rather than trying to find a product to fit you. That makes a huge difference. We’ve got six Ecotexes now and three Duals. The Dual is amazing, you can get a huge volume of digital through a very small area. And Steve, who’s their main engineer, he’s just brilliant, he really knows these machines.”

- Andy, T Shirt & Sons. UK

adelco DIGI-CURE

A **small dryer** with big dryer features and **performance.**

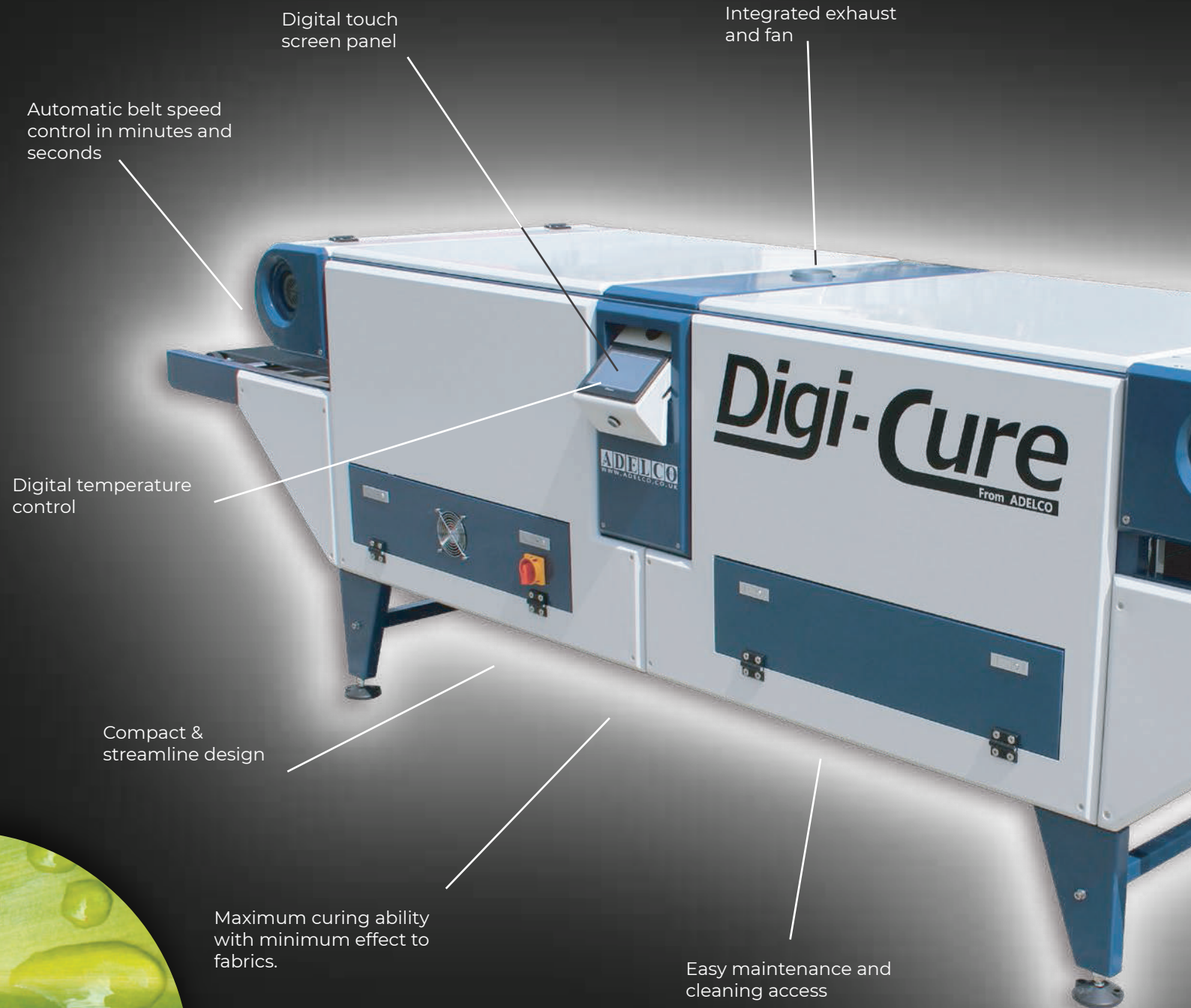

Digital touch screen panel

Integrated exhaust and fan

Automatic belt speed control in minutes and seconds

Digital temperature control

Compact & streamline design

Maximum curing ability with minimum effect to fabrics.

Easy maintenance and cleaning access

The Adelco Digi-Cure dryer is our solution for small to medium production runs. Big performance on a smaller dryer for digital prints, water-based inks and more. The Digi-Cure oven is 2.6 meters with a 90cm in-feed and 90cm outfeed, with 80cm belt width.

While the Digi-Cure may be smaller in size, it includes all the same features as our high production dryers, so you can benefit from the many rich-features of our textile dryer range. This smaller conveyor dryer has a single outlet for extraction, as the ductwork for the exhaust, infeed and outfeed extraction are internal. With just one single exhaust outlet, you will benefit from a cleaner working environment.

The Digi-Cure comes with a touch screen control panel to give you ultimate control over the drying and curing process. You can easily control the belt speed and temperature control of the tunnel for optimal output.



Full 2.6m curing ability

Integrated infeed/outfeed extraction

80cm wide conveyor belt

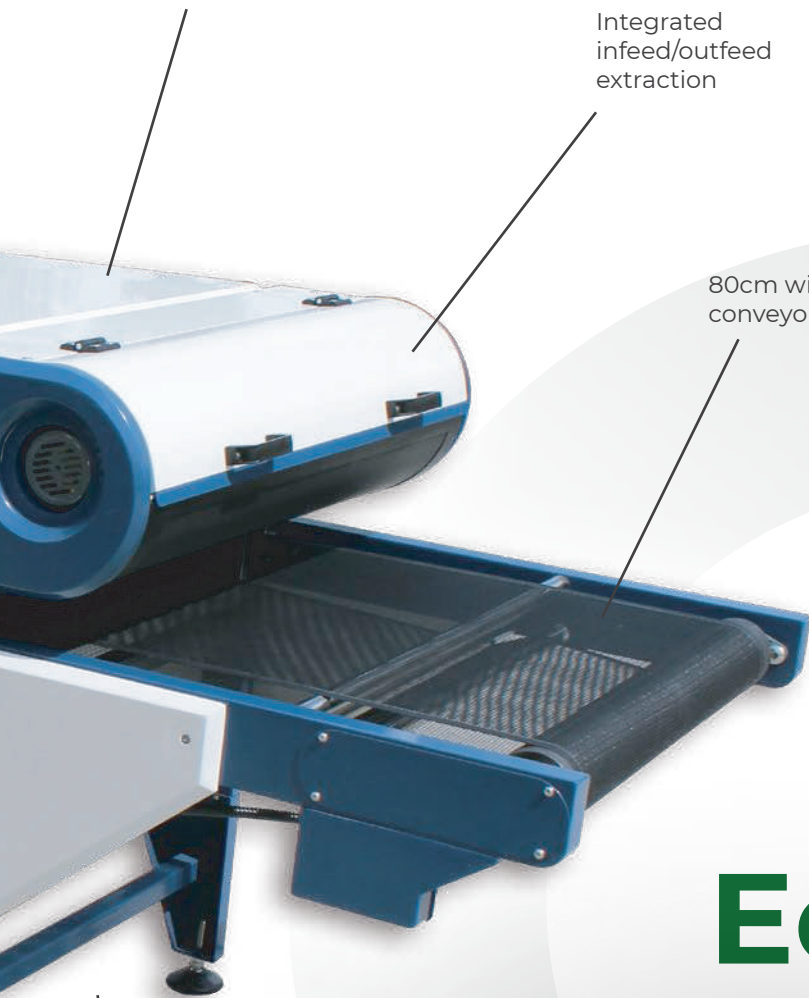

Economical.

High pressure airflow for best possible curing penetration



2.6m

Model No	DC80E-3
Electrical Supply	19KW, 3 Phase 220-240V or 380V-415V, 50/60hz
Belt Speed	50 secs > 10 mins
Time from ambient temp to 160°C (320°F)	Approx 30 mins
Exhaust Diameter	100mm (4")
Belt Width	80cm (32")
Infeed/Outfeed	88cm (35")
Oven Length	260cm (102")
Oven Dimensions (max)	110cm (44") W x 128cm (50") H x 436cm (172") L

Time	Digital Print (Dark Shirts)	Digital Print (Light Shirts)	Screen Print
1 Minute	/	/	300 per hour
2 Minutes	/	150 per hour	150 per hour
3 Minutes	/	100 per hour	100 per hour
4 Minutes	75 per hour	75 per hour	/
5 Minutes	60 per hour	/	/
6 Minutes	50 per hour	/	/
7 Minutes	45 per hour	/	/
8 Minutes	40 per hour	/	/

Based on a single line of adult size garments, allowing for one product placed every 50cm. Production rates will alter depending on product placement and time/temperature settings chosen for individual curing requirements.





“Adelco keeps up with technology and the temperature keeps constant. Service with Adelco is brilliant, Steve looks after us and is always on hand to help out either on the phone or getting stuck in the machines.”

- Pally Hayre, Pally UK



adelco DRAWER DRYING CABINETS

A compact, space-saving and economical solution for the curing of digital and screen printed textile inks.

Automatic Drawer Dryers

Each cabinet incorporates motor driven drawers, operated & controlled by its own cycle timer. Drawers automatically eject for unloading & reloading after the cycle time has counted down. Each drawer is independently controlled via a membrane touch control panel and automatically opens and closes from pre-programmed timers. A digital display counts down the preset times of each independent drawer and shows the time remaining.



DDC-3A



Easy access cleaning - no replacement filters required

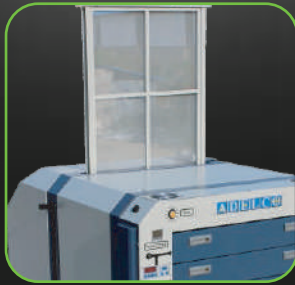

Easy access cleaning - no replacement filters required



DDC-6A

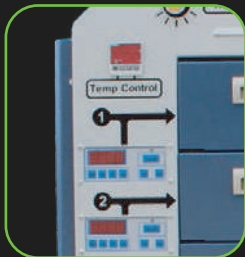

Independent drawer controls



Variable Exhaust

Manual Drawer Dryers

Manually operated draws each with independent timers that give an audible & visual alarm when preset draw times are complete. These units offer a great entry level, low cost solution.



DDC-3M



DDC-6M

Standard Features of All Cabinets

- Digital Temperature Control
- Independent Drawer Timers
- Direct Heated High Velocity Air-Flow
- Permanent Lint Filter (No Replacement Filters Required)
- Variable Exhaust Control
- Hot Air Recirculation
- Easy Load Drawers

Using digitally temperature controlled high velocity air-flow for optimum curing, the DDC balanced air-flow system provides high velocity hot air, directed onto the textile ensuring no loss of heat to the surrounding working area. An efficient and balanced exhaust system ensures removal of all ink and pre-treatment residues in the curing of all digital and screen textile inks.

Three Drawers

The Adelco 3-Drawer drying cabinet offers a compact textile drying solution where DTC printers can be mounted on top of the machine to save even more floor space. Thanks to the drying cabinet's triple insulated exterior and ability to recycle heat for a cool outer skin, there's no residual heat to affect the mounted digital printer, offering the most compact printing and drying solution on the market.

Six Drawers

For increased production requirements, the Adelco Drawer Drying Cabinet also comes available in a six-drawer option. It's ergonomically designed for ease of loading the drawers and each drawer has its own independent digital drawer timer for precise drying times. It has a unique built-in lint filter that can be easily raised above the dryer by a single person, ensuring no further space is required around the dryer and no need for replacement filters.



Throughput Analysis & Supply Requirements

DDC-3 & DDC-6 Specifications

Description	DDC-3A	DDC-3M	DDC-6A	DDC-6A
Drawer operation	Auto	Manual	Auto	Manual
Electrical Requirements	3Phase, 50/60HZ, 200/220V & 380/415V, 13KW Single Phase option available with optional inverter	3Phase, 50/60HZ, 200/220V & 380/415V, 13KW Single Phase option available with optional inverter	3Phase, 50/60HZ, 200/220V & 380/415V, 19KW	3Phase, 50/60HZ, 200/220V & 380/415V, 19KW
Dimensions	151cm(L) x143cm(W) x79cm(H)	158cm(L) x110cm(W) x81cm(H)	153cm(L) x120cm(W) x134cm(H)	158cm(L) x112cm(W) x133cm(H)

DDC-3 & DDC-6 Production (Per Hour)

Description	DDC-3A		DDC-3M		DDC-6A		DDC-6A	
Kornit Digital Inks Based on 160 degrees celcius, 3 mins for light shirts and 6.05 mins for dark shirts. Note - Increased pre-treatment levels will require longer curing times	60 Light	27 Dark	60 Light	27 Dark	120 Light	54 Dark	120 Light	54 Dark
Epson/Brother/Anajet/Polyprint /Dupont Inks at 2 mins	90 Light	90 Dark	90 Light	90 Dark	180 Light	180 Dark	180 Light	180 Dark

Manual drawer versions are available for a more cost conscious solution, however the automatic drawer models are most popular as they enable the operator to concentrate on the print workflow whilst the curing cycle takes care of itself, automatically.

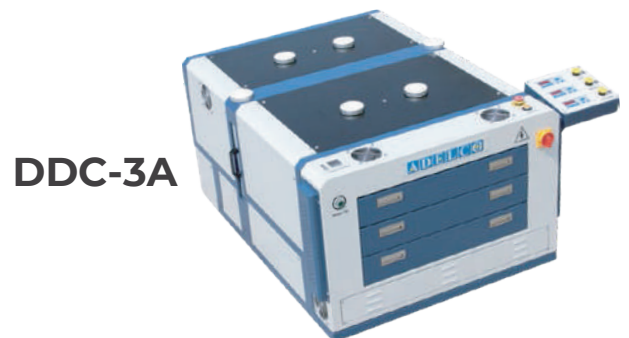

DDC-3 Dimensions

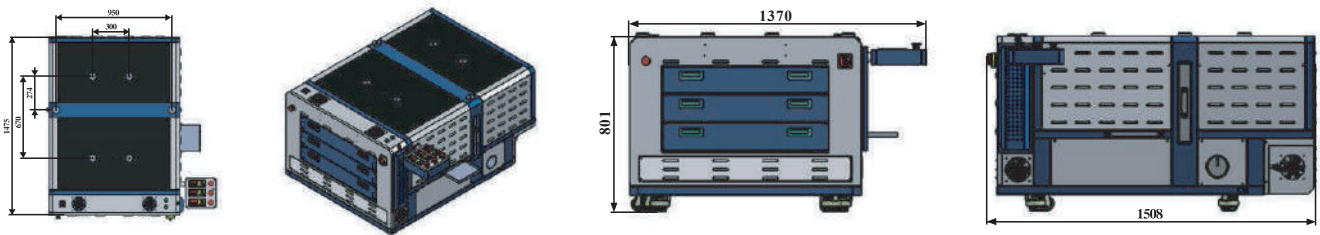

DDC-6 Dimensions

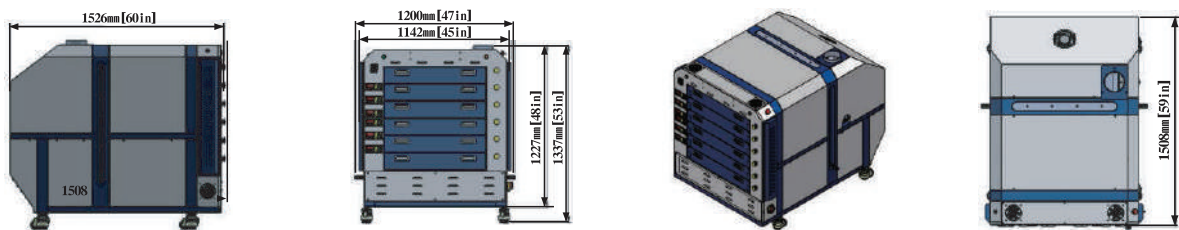

"Adelco dryers have improved the quality of our prints, due to the dryers versatility. The service and technical support that I have received from Adelco over the years have been excellent. Always helpful and available on the phone or on the rare occasion the dryer has needed a service. Our dryer is pretty faultless, other than general wear and tear. I would recommend Adelco and definitely would buy from them in the future.

- Liam Stewart, Vortex Clothing Company Ltd, UK

adelco CYCLONE

The **automatic carousel screen printing press** that offers **incredible value for money with pinpoint precision**. Available in **three standard print sizes**

AC servo motors drive the print head for high torque fast smooth print strokes even at the slowest speed.

Pin Point registration of $\pm 0.02\text{mm}$, designed for the most challenging screen and digital printing.

Optional built in LED lights integrated into the print heads provide unmatched visibility of screens during set up and production.



Three-way front and rear micro screen adjustment for easy set up.

Standard high-grade lightweight aluminium pallets with unique tool free quick release system and CNC print arms with unmatched pallet level tolerances.



PLC controlled with HD touchscreen incorporating advanced features, simple set up and full machine self-diagnosis.

Auto start, stop, sample and rotate flash programmes.

Strong and light custom extruded aluminium print heads and pallet arms gives the perfect strength to weight ratio.

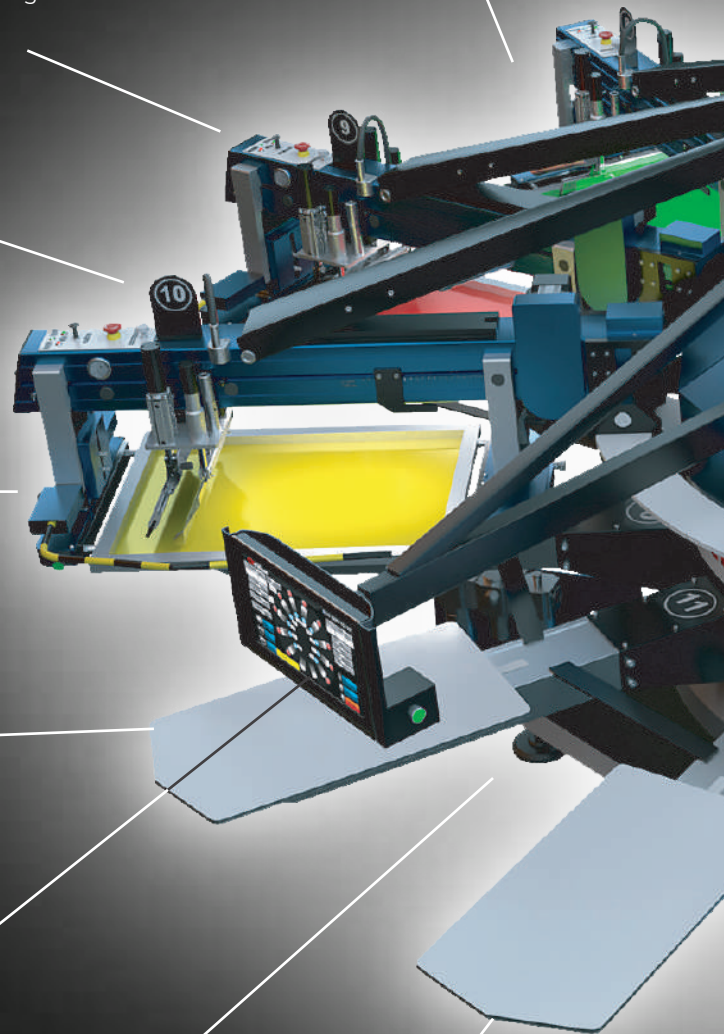

The Adelco Cyclone is an automatic carousel textile screen printing press that offers high-speed printing. The Cyclone is based upon robust, heavy-duty foundations with bespoke lightweight aluminium extrusions and precision CNC parts are fitted with meticulous attention to detail. With its advanced control system, the Cyclone runs pinpoint accuracy at extreme speeds while still offering incredible value for money.

Using the latest advanced technology in textile screen printing, the Cyclone is designed for the most challenging screen printing, with pinpoint registration of $\pm 0.2\text{mm}$. Optional built in LED lights integrate into the print heads to provide unmatched visibility of the screens during set-up and production. The Cyclone uses a rapid lock auto high-lift screen system that provides easy screen cleaning access and loading of flashes into any print head position.

Servo driven main drive gives a fast, smooth index providing speeds in excess of 1000 pieces per hour.

Individual horizontal screen lift at each print head – provides maximum ink stability, better screen visibility and faster loading times as pallets remain at a constant height.

Rapid lock high-lift screen system provides easy screen cleaning access and loading of flashes into any print head position.

Load delay foot pedal

Twin chopper squeegee pressure cylinders provide tool free control of print pressures even with the most viscous ink systems.

Quick lock, tool free squeegees with angle adjustment and flood bars.

The Adelco Cyclone is available in three sizes - small, medium and large. Each comes with different options for the number of colours and print stations so that you can select the best model for your production requirements.

With its servo driven main drive, the Cyclone screen press gives a fast, smooth index that provides print speeds in excess of 1,000 pieces per hour. Even when operating at the lowest speeds, print quality is uncompromised thanks to its AC servo-motors that drive the print head for smooth print strokes. It also comes with strong and light custom extruded aluminium print heads and pallet arms, providing the perfect strength to weight ratio.

Carousel - S Models

Model	No of Colours	No of Stations	Max Print Area	Max Screen Size	Diameter	Standard Pallet Size	Standard Sq/FI Size	Air Supply 8bar (115psi)	Electrical Supply
CYA-6/8-4550	6	8	45x50cm (18"x20")	58.5x78.8cm (23"x31")	343cm (135")	47x72cmm (18.5"x28")	47cm	23.6m ³ /h (13.9cfm)	1P220V/6.8KW
CYA-8/10-4550	8	10	45x50cm (18"x20")	58.5x78.8cm (23"x31")	389cm (153")	47x72cmm (18.5"x28")	47cm	31m ³ /h (18.3cfm)	1P220V/8.3KW
CYA-10/12-4550	10	12	45x50cm (18"x20")	58.5x78.8cm (23"x31")	430cm (169")	47x72cmm (18.5"x28")	47cm	38.6m ³ /h (22.72cfm)	1P220V/9.8KW
CYA-12/14-4550	12	14	45x50cm (18"x20")	58.5x78.8cm (23"x31")	472cm (186")	47x72cmm (18.5"x28")	47cm	46m ³ /h (27.1cfm)	1P220V/11.3KW
CYA-14/16-4550	14	16	45x50cm (18"x20")	58.5x78.8cm (23"x31")	513cm (202")	47x72cmm (18.5"x28")	47cm	53.5m ³ /h (31.5cfm)	1P220V/12.8KW

Carousel - M Models

Model	No of Colours	No of Stations	Max Print Area	Max Screen Size	Diameter	Standard Pallet Size	Standard Sq/FI Size	Air Supply 8bar (115psi)	Electrical Supply
CYA-8/10-5070	8	10	50x70cm (20"x28")	63.5x99.2cm (25"x39")	446cm (175")	52x92cmm (20"x36")	52cm	31m ³ /h (18.3cfm)	1P220V/8.3KW
CYA-10/12-5070	10	12	50x70cm (20"x28")	63.5x99.2cm (25"x39")	490cm (193")	52x92cmm (20"x36")	52cm	38.6m ³ /h (22.72cfm)	1P220V/9.8KW
CYA-12/14-5070	12	14	50x70cm (20"x28")	63.5x99.2cm (25"x39")	535cm (210")	52x92cmm (20"x36")	52cm	46m ³ /h (27.1cfm)	1P220V/11.3KW
CYA-14/16-5070	14	16	50x70cm (20"x28")	63.5x99.2cm (25"x39")	579cm (228")	52x92cmm (20"x36")	52cm	53.5m ³ /h (31.5cfm)	1P220V/12.8KW

Carousel - L Models

Model	No of Colours	No of Stations	Max Print Area	Max Screen Size	Diameter	Standard Pallet Size	Standard Sq/FI Size	Air Supply 8bar (115psi)	Electrical Supply
CYA-8/10-6080	8	10	60x80cm (23.5"x31.5")	74x109cm (29"x43")	498cm (196")	62x102cmm (24"x40")	62cm	31m ³ /h (18.3cfm)	1P220V/8.3KW
CYA-10/12-6080	10	12	60x80cm (23.5"x31.5")	74x109cm (29"x43")	550cm (217")	62x102cmm (24"x40")	62cm	38.6m ³ /h (22.72cfm)	1P220V/9.8KW
CYA-12/14-6080	12	14	60x80cm (23.5"x31.5")	74x109cm (29"x43")	601cm (237")	62x102cmm (24"x40")	62cm	46m ³ /h (27.1cfm)	1P220V/11.3KW
CYA-14/16-6080	14	16	60x80cm (23.5"x31.5")	74x109cm (29"x43")	652cm (257")	62x102cmm (24"x40")	62cm	53.5m ³ /h (31.5cfm)	1P220V/12.8KW



Easily position
Flash Cures into
any print head



“My experience with Adelco has been fantastic and I would recommend Adelco and their products to anyone. I have known Mark a long time and would consider him a friend more than just a business contact. He is someone we can trust, honest to his word, and if he says he is going to do something he does.

- Jon Lunt, T Shirt & Sons. UK

adelco MATRIX

A modular oval screen printer that provides more versatility and high-production output.

Modular design for future expansion

Servo driven index

Fast, smooth & quiet chainless rail system

Sealed print arms

Servo driven print heads

Quick release horizontal pneumatic screen clamping

Large bore squeegee cylinders

Quick-fit tool free squeegee & Flood-blades

Front & rear tool-free micro adjustment

Advanced PLC control system & HDMI touch screen



High density print mode

Auto lift print heads

Rigid CNC machine pallet arms

Easy tool-free front & rear off contact adjustment

High grade aluminium quick-release pallets

Safe, Modular, Expandable.

The Matrix Oval screen printing machine from Adelco offers a more efficient use of space thanks to its oval-shaped design. It offers greater stability with larger print formats than comparable carousel based machines. The Matrix Oval provides more versatility with multiple flashes, cooling and speciality print stations, providing the highest print quality and accuracy.

Available in three standard print size formats, the Matrix can be configured for almost any production requirement with an infinite number of pallets and print stations. Its servo driven print heads enable cycle times in excess of 900 prints per hour.

It has a unique rail and drive system that ensures almost silent operation, creating a quiet print-shop environment.

Pallets are securely locked with hardened locators. Indexing to an accuracy of +/- 0.02mm.

Safety barriers, proximity sensors, and safety lasers run the full length of the machine that immediately stops the machine if activated. The Matrix Oval is designed with safety as a priority, with worldwide renowned certification.

The Matrix Oval offers unparalleled support of print heads & pallet arms during print cycle for exceptional print quality and repeatability.

Electrical Requirements	
<28 stations	>28 stations
1 phase 220V 2KW + 750W per print head	1 phase 220V 4KW + 750W per print head

Air Supply	
Pressure	CFM (per print head)
100PSI/7bar	3 CFM

Standard Image Area	Max Frame Size	Max Machine Width	Length
45x60cm (18"x24")	64x100cm (27"x43")	363cm (143")	Depends on format
50x70(20"x28")	69x110cm (27"x43")	398cm (157")	Depends on format
60x80cm (23.5"x31.5")	79x120cm (31"x47")	418cm (165")	Depends on format

Print-Flash-Cool Format

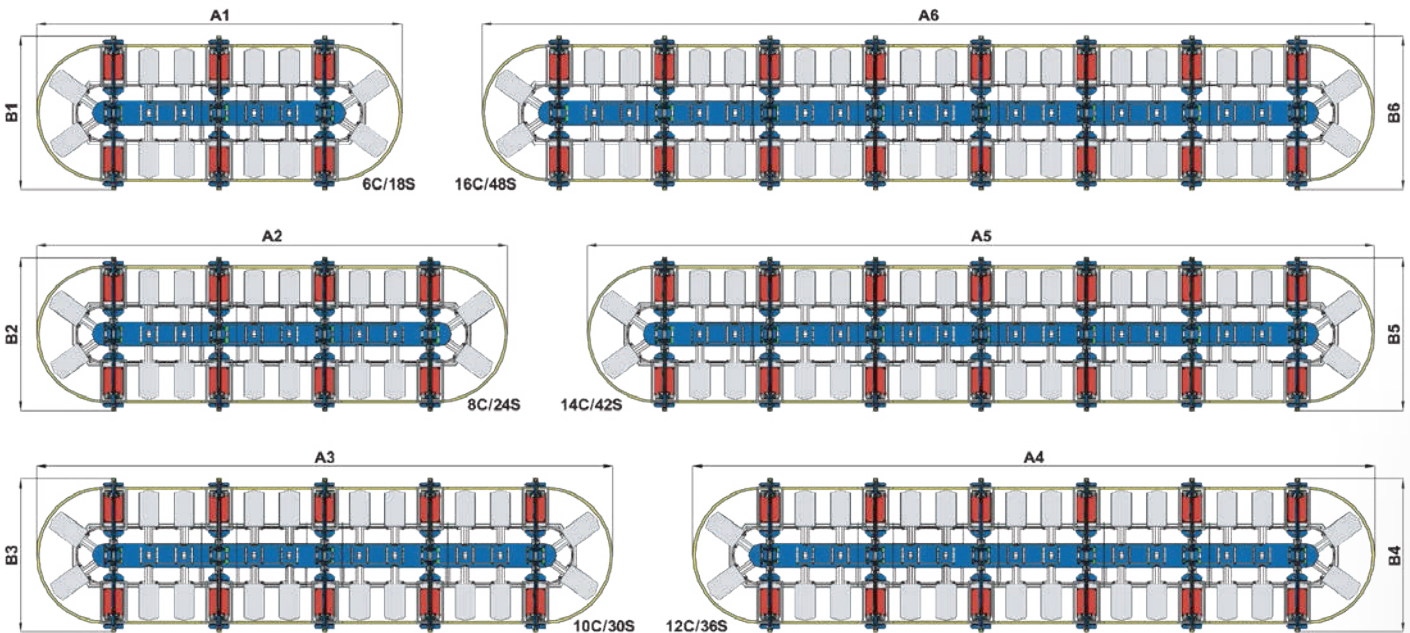

Model	6C/18S		8C/24S		10C/30S		12C/36S		14C/42S		16C/48S	
	A1	B1	A2	B2	A3	B3	A4	B4	A5	B5	A6	B6
MTX 4560	8.68M	3.63M	11.12M	3.63M	13.55M	3.63M	15.99M	3.63M	18.45M	3.63M	20.87M	3.63M
MTX 5070	9.48M	3.98M	12.23M	3.98M	14.97M	3.98M	17.71M	3.98M	20.45M	3.98M	23.19M	3.98M
MTX 6080	9.68M	4.18M	12.43M	4.18M	15.17M	4.18M	17.91M	4.18M	20.65M	4.18M	23.39M	4.18M

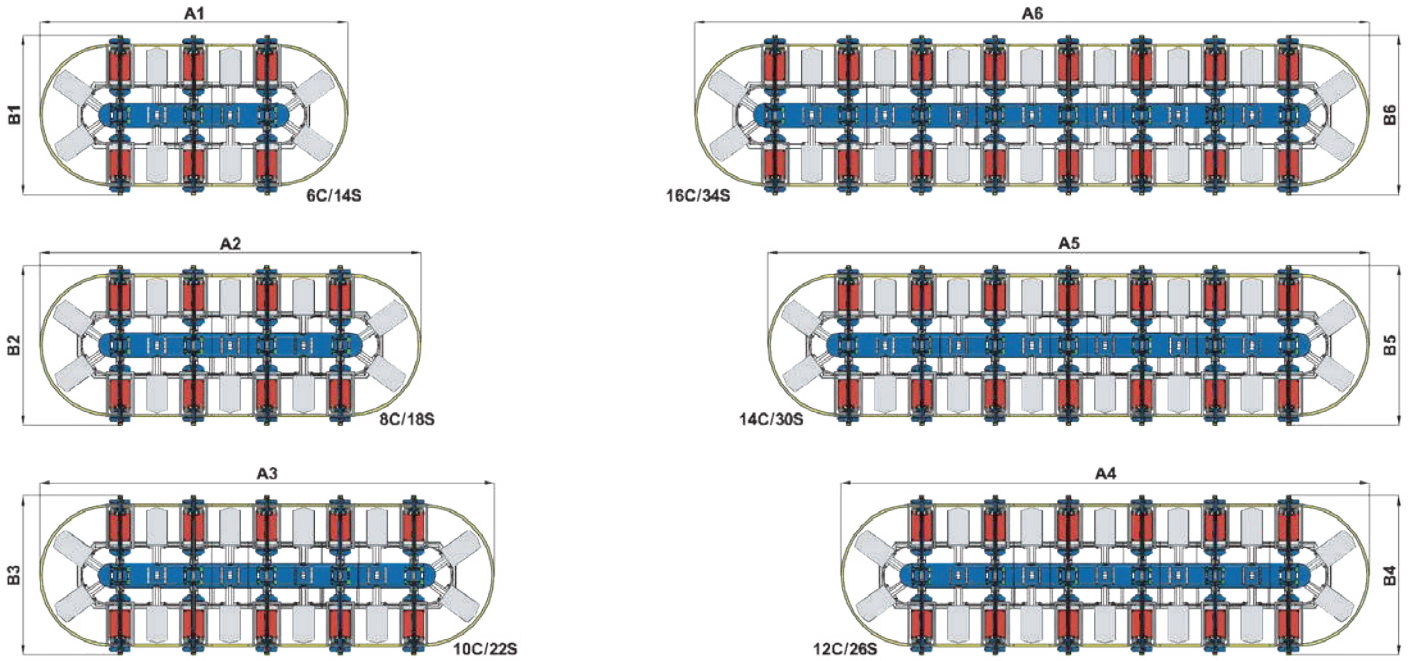

Model	6C/14S		8C/18S		10C/22S		12C/26S		14C/30S		16C/34S	
	A1	B1	A2	B2	A3	B3	A4	B4	A5	B5	A6	B6
MTX 4560	7.05M	3.63M	8.68M	3.63M	10.30M	3.63M	11.93M	3.63M	13.55M	3.63M	15.18M	3.63M
MTX 5070	7.66M	3.98M	9.48M	3.98M	11.31M	3.98M	13.14M	3.98M	14.97M	3.98M	16.80M	3.98M
MTX 6080	7.86M	4.18M	9.68M	4.18M	11.51M	4.18M	13.34M	4.18M	15.17M	4.18M	17.00M	4.18M

Works with the Adelco high speed digital hybrid printer option

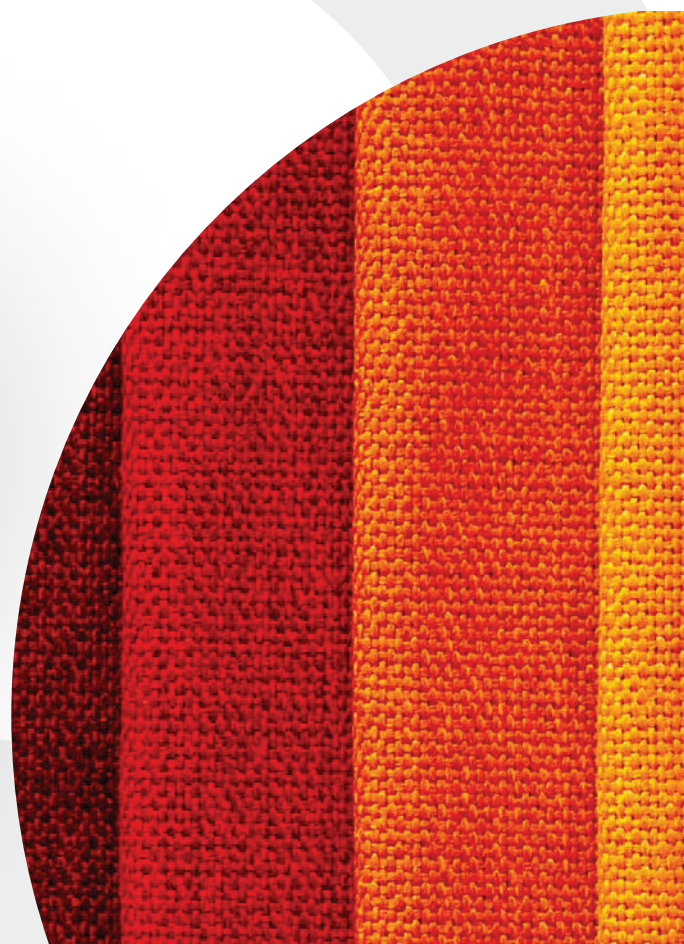

adelco ELLIPSE

Unique in the market place having **front and rear registration locators** and **pallet support** providing **the most stable and accurate registration** on extra large print areas

Strong and stable structure

Modular & Expandable

High Production

Smooth, Quiet Operation

Most effective use of space

Precision in motion

Designed with self diagnostics and simple maintenance

Optional extras including:

- Digital docking station
- Humidifier
- Flocking
- Hot Iron

The Adelco Ellipse Oval can be configured for almost any screen-printing production requirement with an infinite number of stations and print heads. With its' modular make-up, this screen printer can be easily scaled up as your business and print requirements grow. The best solution for print areas of 70x100cm and above with a high power servo index, allowing for cycle times of 700 or more prints per hour.

Precision printing is achieved using the Ellipse Oval, as pallets are locked front and back, offering accuracy of +/- 0.02mm. The Ellipse Oval also features a unique floating pallet design, which is chainless for extreme longevity and smooth pallet index.

The Ellipse Oval features an advanced PLC control system with human interface for all operator functions including auto start and auto finish.

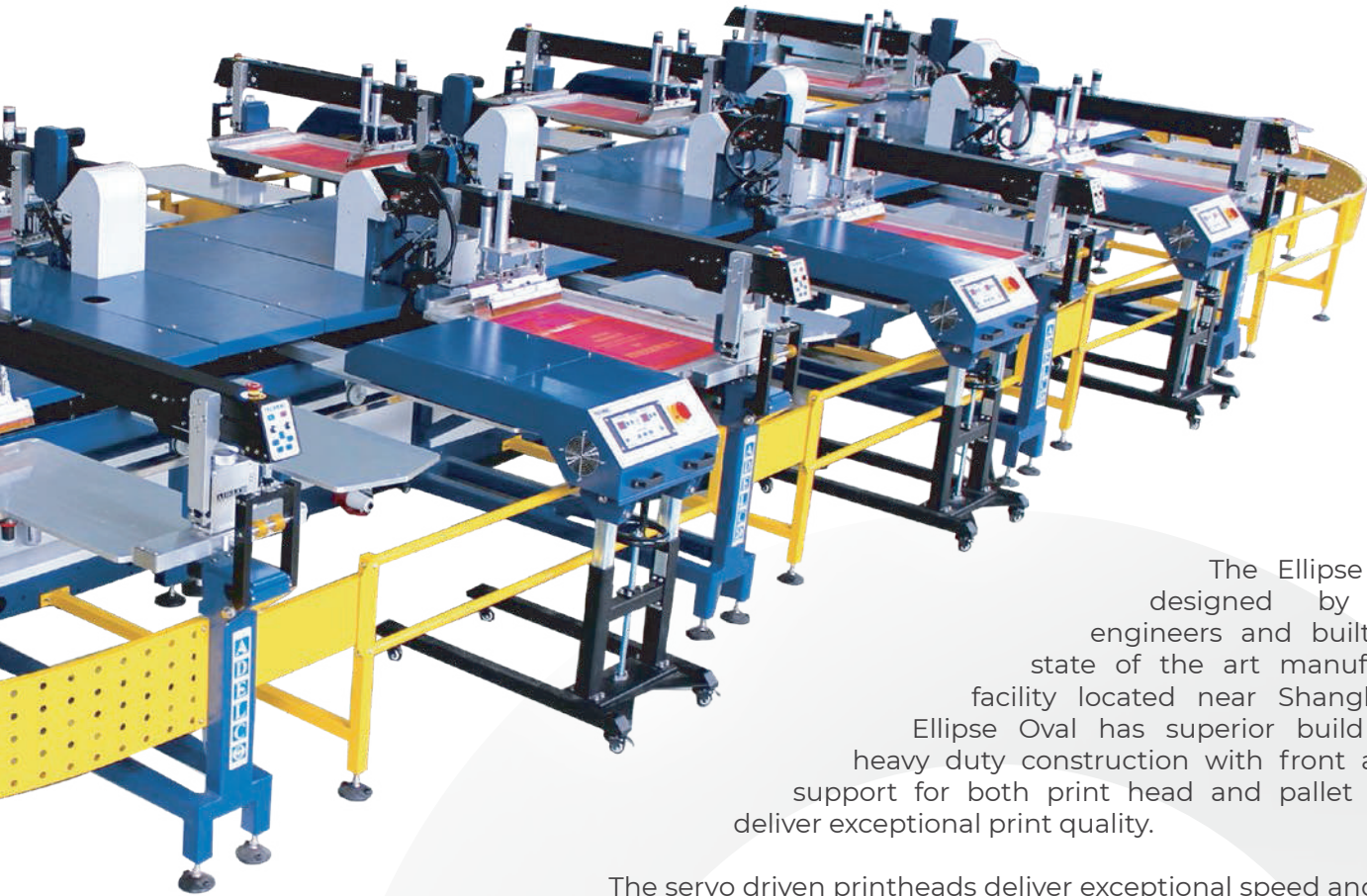

The Ellipse Oval is designed by British engineers and built at our state of the art manufacturing facility located near Shanghai. The Ellipse Oval has superior build quality, heavy duty construction with front and rear support for both print head and pallet arms to deliver exceptional print quality.

The servo driven printheads deliver exceptional speed and control torque, and feature adjustable screen chase, three-way responsive micro registration, quick release squeegee/flood blades, front and rear off contact and levelling adjustment, and a quick release high lift facility for rapid screen cleaning or flash cure docking.

Every printer head is fitted with a touch panel control for all main printing functions. Rigid pallet arms optimising servo index, supported front and back during the print cycle provide zero pallet deflection, while at Adelco we also offer a wide range of easily removable pallet style and sizes.

Features

- Chainless pallet drive system for extreme longevity and smooth pallet index.
- Guaranteed lifetime registration. Our unique lock system which is located on every pallet arm, disengages the pallet from the drive mechanism ensuring consistent pin-point lifetime registration.
- Servo driven printheads delivering exceptional speed and control torque, even at lower speeds our printheads feature adjustable screen chase, three-way responsive micro-registration, quick release squeegee/flood blades, front and rear off-contact and levelling adjustment, a quick release high lift facility for rapid screen cleaning or flash cure docking. Every head is fitted with a touch panel control for all main printing functions.
- Rigid pallet arms optimizing servo index, supported front and back during the print cycle providing zero pallet deflection. We offer a wide range of easily removable pallet styles and sizes.
- Superior build quality, heavy duty construction for both print head and pallet arms delivering exceptional print quality.
- 2 year limited warranty – The Ellipse Oval is covered by a 2 limited year warranty and supported by our global network of service agents and distributors

Electrical Requirements	
<28 stations	>28 stations
1 phase 220V 1.5KW + 700W per print head	1 phase 220V 2.5KW + 700W per print head

Air Supply	
Pressure	CFM (per print head)
100PSI/7bar	3 CFM

Standard Image Area	Max Frame Size	Max Machine Width	Length
70x100cm (28"x39")	89x140cm (35"x55")	440cm (173")	Depends on format
80x120cm (31.5"x47.2")	99x160cm (39"x63")	480cm (189")	Depends on format

Larger print sizes quoted on request

Print-Flash Format

Model	6C/14S		8C/18S		10C/22S		12C/26S		14C/30S		16C/34S	
	A1	B1	A2	B2	A3	B3	A4	B4	A5	B5	A6	B6
OVAL70100	8.92M	4.4M	11.05M	4.4M	13.18M	4.4M	15.32M	4.4M	17.45M	4.4M	19.59M	4.4M
OVAL80120	10.01M	4.8M	12.29M	4.8M	14.58M	4.8M	16.87M	4.8M	19.15M	4.8M	21.44M	4.8M

Larger print sizes quoted on request

Print-Flash-Cool Format

Model	6C/20S		8C/26S		10C/32S		12C/38S		14C/44S		16C/50S	
	A1	B1	A2	B2	A3	B3	A4	B4	A5	B5	A6	B6
OVAL70100	11.05M	4.4M	14.25M	4.4M	17.45M	4.4M	20.65M	4.4M	23.85M	4.4M	27.06M	4.4M
OVAL80120	12.09M	4.8M	15.75M	4.8M	19.15M	4.8M	22.58M	5.35M	26.01M	5.35M	29.44M	5.35M

Larger print sizes quoted on request

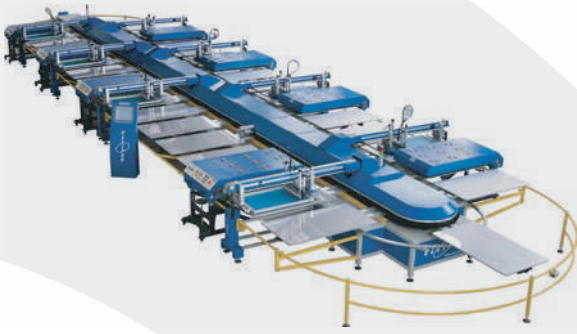

Model No: OPP-8C36S-80120
8 colour - 36 Station
80x120cm Printing Area

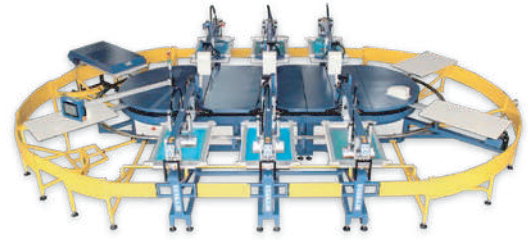

Model No: OPP-6C10S-70100
6 colour - 10 Station
70x100cm Printing Area



Bespoke oval design auto
sock printer illustrated



"I would recommend any of the Adelco products to anyone, not only for the quality, but definitely for the support offered after the sale."

- Rob Dubow, Dubow Textile Inc. USA

adelco AD HYBRID DIGITAL

A high-speed digital textile printer that works seamlessly with our automatic screen printing presses with the lowest ink cost per print.

4 & 6 colour model options available

Printing resolutions of up to 600 x 2400 dpi

Prints on fabrics including cotton, linen, silk, nylon, polyester and more.

Softest hand feel on the market

Easy to maintain print heads.

Worldwide support network.

Market leading finish.

Bolt on product for the Matrix and Ellipse Oval screen printers.

Capable of printing up to 300 pieces per hour.

Unique design to ensure the printer does not take up too much space

Built in humidifier and ink recirculation system.

Environmentally friendly inks



Adelco's Hybrid Digital system is an add-on High Speed Digital Station designed to work in conjunction with the Adelco Automatic Screen Printing Presses, the Matrix Oval and Ellipse Oval. This Hybrid digital system combines the advantages of both screen and digital printing to create even the most innovative garment decoration.

Utilising environmentally friendly inks, Adelco's AD Hybrid Digital can produce A4 format printed substrates in excess of 300 units per hour, and when used in conjunction with a screen printed base providing the lowest ink cost per print.

Using industrial grade Spectra StarFire print heads for maximum stability, durability and reliability, Adelco's AD Hybrid Digital solution can achieve complex designs. The system is quick to set up and prints quickly without the need for costly separations or screen manufacture.

Combine digital print, spot colour, high build, glitter, puff, flock, foil and other special effect prints all on one print machine. The Adelco AD Hybrid has a built in humidifier and ink recirculation system.

- A4 print up to 300 per hour
- Softest hand feel on the market
- Worldwide support network
- Environmentally friendly inks
- Industrial grade Spectra StarFire print heads



A digital add-on for the Matrix and Ellipse.

Digital Printer Model	AD-7070-4
	AD-7070-6
Colour	4/6 colour
Printing Resolution	600x800dpi, 600x1000dpi, 600x1200dpi
Highest Printing Resolution	600x2400dpi
Printing Fabric	Cotton, linen, silk, nylon, polyester, viscose, etc.
Max Printing Area	700x700mm
Max Speed	350pcs/h
Ink Type	Pigment Ink
Max Medium Thickness	25mm
Ink Supply System	Auto negative pressure ink supply system
Ink Capacity	5L/colour
RIP Software	Photoprint. Neostampa
Printhead Maintenance	Self-Cleaning
	Auto Ink Wiping System
	Built in Humidifier
	Built in Ink Recirculation System
Power Supply	220vAC, single phase, 50/60hz
Work Environment	Temperature 25-28°C, Humidity, 55%-65%
Print Heads	4 Colour - 12x512 nozzle Fujifilm StarFire print head modules
	6 Colour - 16x512 nozzle Fujifilm StarFire print head modules
Weight of Machine Packaging	1,800kg
Size of Machine Packaging	4000x2380x2300mm



adelco FLASH CURE

High-spec **flash cure units** that use cutting edge quartz infra-red lamps, unique hot air modules and more **for all your screen and digital printing requirements.**



MTX-5070

- Rapid cure, medium wave quartz lamps
- Variable power output
- Variable process time
- Three and nine independent zones

Adelco produce a wide range of high specification Flash Cures and Table Drying Units to suit every application. Utilizing leading edge quartz infra-red lamps and unique hot air modules, we have a flash cure solution for all your screen printing and digital requirements.

- Universally adjustable to interface with most automatic and manual carousels
- Automatic control from direct pin connection to Adelco printers or via optional pallet sensor for use with other equipment manufacturers



MTX-6080



OFC-4560



MTX-5070

Flash cure units for your screen printers.

Oval Flash Cures

Model	Compatible Machines	Curing Area	KW (380V)	Stand Mounted
OFC-4560	Stand mounted, thee zones, automatic, quartz	45x60cm (18x23")	13.5	Yes
OFC-5070	Stand mounted, thee zones, automatic, quartz	50x70cm (21x27")	18	Yes
OFC-6080	Stand mounted, thee zones, automatic, quartz	60x80cm (23x31")	18	Yes
OFC-70100	Stand mounted, thee zones, automatic, quartz	70x100cm (27x40")	22.5	Yes
MTX-4560	M&R, TAS, Schenk etc.	45x60cm (18x23")	13.5	Yes
MTX-5070	M&R, TAS, Schenk etc.	50x70cm (21x27")	18	Yes
MTX-6080	M&R, TAS, Schenk etc.	60x80cm (23x31")	18	Yes
MTX-70100	M&R, TAS, Schenk etc.	70x100cm (27x40")	22.5	Yes

Automatic Quartz Flash Cure Units

Model	Compatible Machines	Curing Area	KW (380V)	Stand Mounted
AFC-4050	MHM E-Type	40x50cm (15x19")	9	-
AFQ-4560	MHM S-Type, Schenk, Hebbeker	45x60cm (18x23")	13.5	-
AFQ-5070	MHM 3000/4000 Schenk, Hebbeker	50x70cm (21x27")	18	-
AFQ-70100	Jumbo MHM Hebbeker 3000/4000 Shenk, Hebbeker	70x100cm (27x40")	22.5	-
AFQ-80110	Super Jumbo MHM	80x110cm (31x43")	22.5	-
AMR-4560	M&R, TAS, Shenk etc.	45x55cm (18x21")	13.5	Yes
AMR-5070	M&R, TAS, Shenk etc.	50x70cm (21x27")	18	Yes
AMR-70100	M&R, TAS, Shenk etc.	70x100cm (27x40")	22.5	Yes

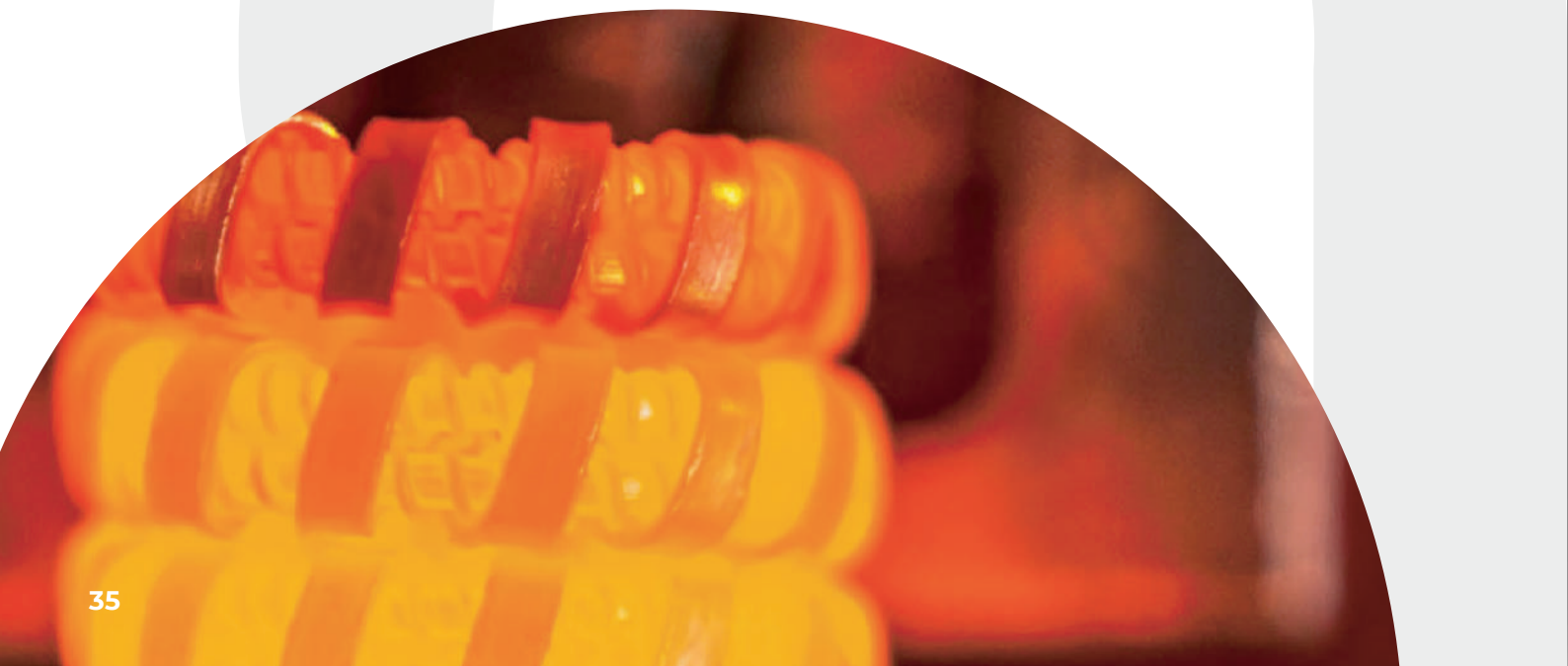

Manual Flash Cures, Stand Mounted

Model	Curing Type	Compatible Machines	Curing Area
AMF-4560	Long Wave Infra Red	Manual Carousels	45x60cm
AMF-5070	Long Wave Infra Red	Manual Carousels	50x70cm
AMR-4560	Automatic, Quartz	Manual Carousels	40x60cm
AMR-5070	Automatic, Quartz	Manual Carousels	50x70cm

Jet Air Flash Cures

Maximises intermediate drying of water based inks and reduces dye sublimation on polyester and other acrylic materials

Model	Compatible Machines	Curing Area
JFC-4555	Mounted in print head, driven by squeegee head & interfaces with printer controls	45x55cm (18x27")
JFC-5070	Mounted in print head, driven by squeegee head & interfaces with printer controls	50x70cm (21x27")
JFC-4555SD	Stand mounted with independent hot air module drive & pallet sensor	45x55cm (18x21")
JFC-5070SD	Stand mounted with independent hot air module drive & pallet sensor	50x70cm (21x27")

“We have been working with Adelco for the past 7 years and have found them to be the most reliable and efficient solution to all of our dryer requirements. The products are all superbly constructed and perform optimally in even the most testing environments. We have installed their products all over South Africa and the Indian Ocean and can honestly say that their reliability is exceptional! When we have on odd occasions, had small issues, the support and after-sales service of the Adelco Team is fast and efficient. We would have no hesitation in recommending and selling any of their products to any of our valued clients.”

- Steve Harcourt-Wood, REXX Screen & Digital Supplies

OVALJET

OVALJET
OVALJET



Upto 240 Prints Per Hour
Ultra High Quality DTG
Incredibly Low Cost Per Print

A revolutionary closed loop high volume direct to garment printer. A new way of digital printing

adelco
SUPPLIED BY 

Fast, Quality, Low Cost.

- Digital White Cabinet
- Digital Colour Cabinet
- Dot-for-Dot Inline Digital Pretreatment
- Multi-Stage Smart Cure Intermediate Drying
- Inline Heat Press Flattens Fibres
- Inline Neck Print
- Automatic Bar Code Reader and File Loading
- Turbine Mobile App

Adelco are delighted to announce exclusivity to supply and support OvalJet in the UK

The OvalJet is a revolutionary closed loop high volume DTG printer. Producing unmatched colour vibrancy using our 7 colour digital printing (CMYKRG+W), superior wash durability and the fastest print speeds in the industry. Designed in an oval shape similar to screen printing with the dynamic capabilities of 100% Digital application.

Able to print up to 240 garments per hour, with a single operator utilising a single ink set for all substrates. Exceptional efficiency and cost effectiveness.

Pre-treat in-line with the machine

OvalJet's resin based foundation (Pre-treat) digitally prints the foundation identical to the printed image. This patented process eliminates the square box, staining and smell associated with other pre-treat processes. It also allows a variety of different substrates that you are able to offer to your customers.

Print Costs & Speed

Print cost is half of that of our direct competitors. Approximately £0.45 per print. The screen printing oval design moves each garment through a sequence of automated stations that prepares and prints the garments. This allows one operator to achieve full size, full colour prints at twice the speed of its rivals.

Inline neck tag printing

In the same pass the OvalJet also prints the neck label, enabling 100% digital variable, complete branding with no additional handling. This unique process is patent protected.

Print Rate	Up to 240+ per hour
Print Heads	Ricoh Gen 5 (CMYKRG & W)
Main Print Area	40 x 48 cm (16 x 19 in)
Max Resolution	600 x 2400 DPI : 800 x 1800 DPI
Dimensions	L: 7.3 meters, W: 4.8 meters, H: 2.1meters
Compressed Air	100 PSI : 7 Bar
Power	63 KW - 3 phase 208V
Temperature	68°F - 82°F



thermotron
TEXTILE MACHINERY

Folding, bagging and stacking textile machines for increased productivity.

thermotron **FX25s**
AUTOMATIC FOLDING MACHINE



thermotron **FX25**
AUTOMATIC FOLDING MACHINE

- Fold garments quickly, quietly and precisely
- Only 1 operator required
- Fold T-shirts, sweatshirts, sweaters, undershirts, etc.
- Adjustable for the various sizes and types of garments
- Both machines provide a program for easy packaging of the garment in a plastic bag.

adelco
SUPPLIED BY

thermotron

Modular Range

All machines are offered and operate as autonomous units or as modules of a full station.

STP1000

AUTOMATIC FOLDING MACHINE

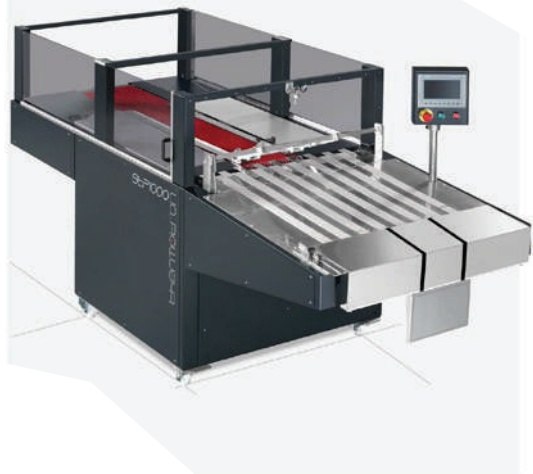

The STP-1000 is the updated version of the successful automatic folding machine STP-950, which was globally marketed in past years. To the new STP-1000, Thermotron have installed state-of-the-art pneumatic, electrical and electronic systems aiming at the even higher quality of its construction and ergonomics.

The automatic folding machine STP-1000 folds ready-made clothes quickly, silently and with precision. It requires just one operator and it is designed to perfectly fold t-shirts. It can be easily adjusted to fold various types and sizes of clothes, within the permissible limits.

A maximum production capacity of 5500 garments per 8 hours.

PV40 is the new automatic bagging machine for garments and constitutes an evolution of its predecessor PV38. With targeted improvements and with a detachable transport belt according to the customer's needs.

The output capacity of PV40 depends on the output speed of STP1000 or on how fast the operator places the garments in the machine when the machine functions independently.

The new automatic PV40, bags garments that come already folded from the automatic folding machine STP1000, into polyethylene (PE) bags in the form of an envelope. If more than one garment needs to be placed in a bag, PV40 can be used independently and the operator can place the garment in the machine manually.

PV40

AUTOMATIC BAGGING MACHINE



KL60

AUTOMATIC SEALING MACHINE



The KL-60 is an automatic sealing machine that closes the bags that contain clothes folded and packaged from the automatic folding machine STP-1000, and the bagging machine PV-40.

The machine gives the operator the option to close the bag either with one adhesive tape in its centre or with two tapes at its two ends.

thermotron

Modular Range Continued

BC41

AUTOMATIC LABEL PRINTING AND ATTACHING MACHINE



A new product from Thermotron, a barcode-machine, that prints and attaches labels to plastic bags. When the bags leave the PV40 bagging machine it attaches labels easily and efficiently to plastic bags.

The output capacity of this machine depends on the output speed of the STP1000 folding machine and the speed of the operator.



The NT50 is an automatic stacking machine. The NT50 stacks the already folded garments as they come from the STP1000 automatic folding machine. It can stack folded garments with maximum fold dimensions of width 18 to 32cm, with a maximum stack height of 35cm.

The NT50 is a robust construction that requires very little maintenance and is designed as an alternative to the PV38 bagging machine by Thermotron. The NT50 can stack the garments in bundles, the size of the stack is selected from the touch screen in front of the automatic folding machine STP1000. When the NT50 piled the desired number of garments that are chosen, they are automatically pushed onto the conveyor belt.

NT50

AUTOMATIC STACKING MACHINE



Available Combinations

The Complete Station - Folding, Bagging, Sealing, Labelling



Folding, Bagging and Sealing



Folding and Bagging



Folding and Stacking

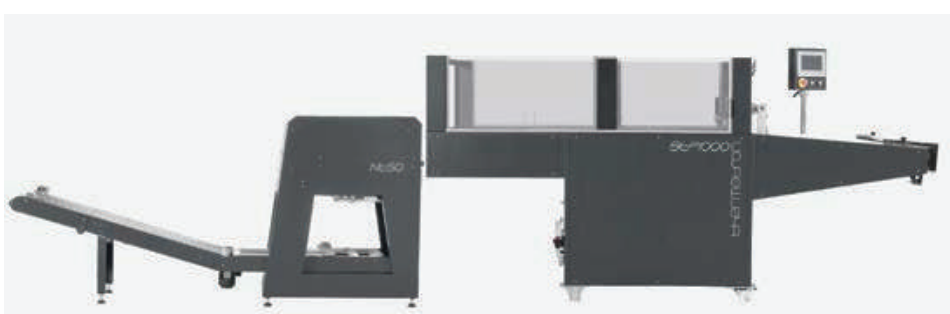

adelco SPYDER II

The **direct to screen system** offers a streamlined interface, increased speed, greater mechanical precision and production efficiency.

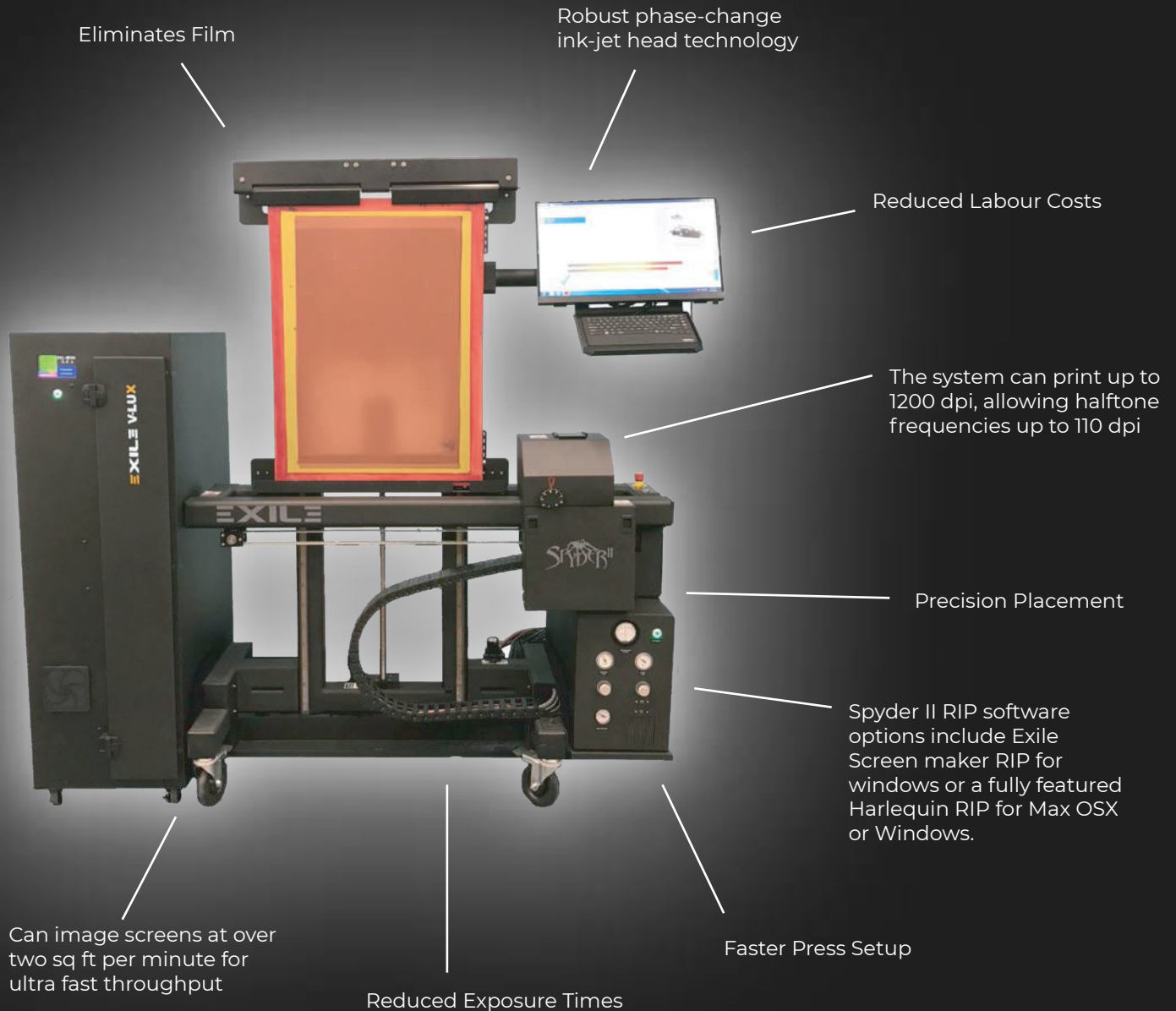

adelco ANCILLARIES

adelco
CYCLONE SEMI-AUTO

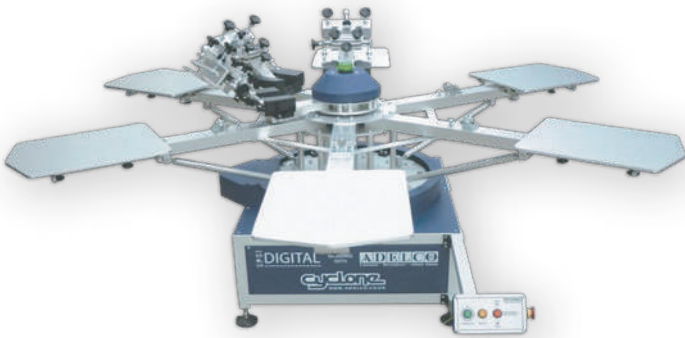

adelco
MANUAL CAROUSEL

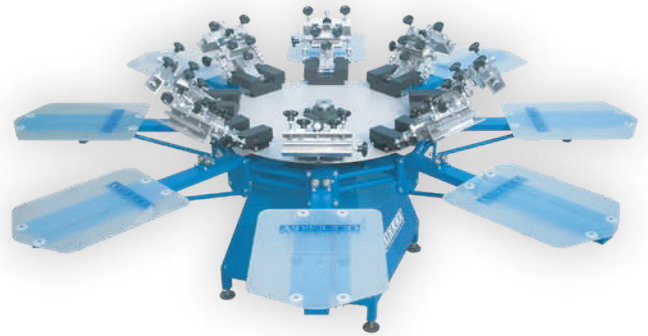

adelco
TEMPERATURE MAPPING KITS



adelco
PRE-REGISTRATION SYSTEM



adelco
TABLE FLASH



adelco
AUTO FLOCK UNIT



adelco
FLOCK CLEANER



adelco
INK PROCESSOR



EXILE
TECHNOLOGIES

V-LUX

SUPPLIED BY **adelco**

The V-Lux is a high powered, vertical free-standing UV Led exposure system built specifically to compliment the Spyder II computer to screen system.



www.adelco.co.uk

UK Unit 18 Highview, Highstreet, Bordon, Hants., England, GU35 0AX

Tel: +44(0)1420 488 388

Fax: +44(0)1420 476 445

CHINA No. 445, Wangshi Road, Lujia, Kunshan, 215300, China

Tel: +86(512)5747 0308

